



A CRANE WHICH MOVES WITH YOU!

KITO PORTABLE CRANE SYSTEM PORTAL CRANE + EQ SERIES ELECTRIC CHAIN HOIST

SMOOTH

KITO EQ series electric chain hoists with dual speed Inverters & ALU Rail ensure smooth movement (Vertical & Horizontal). This helps in reducing load bouncing.

SAFE

Electronic overload prevention device (E-OLL) is provided as a standard. This device stops operation immediately whenever an abnormal load is detected

LONG LIFE

With M6 rating, KITO EQ series electric chain hoists achieve a very long life. This results in high cost performance.

Ideal to be used with
KITO Electric Chain Hoists
and
KITO Chain Pulley Blocks

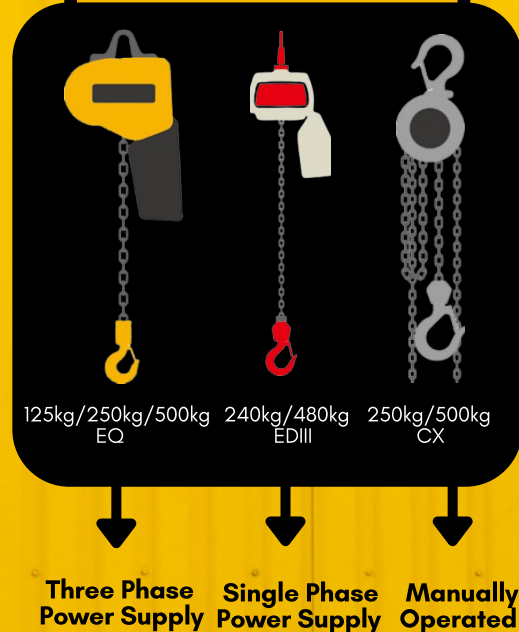

TECHNICAL SPECIFICATIONS FOR PORTABLE CRANE SYSTEMS

Sl No.	Portable Crane (Single Girder)							
	Capacity (kg)	Model	Profile	Span: LKr (mm)	Height: Ho (mm)	Length: LHT (mm)	Top Height: h (mm)	Width: W (mm)
1	125	PASP001	Alu3	4500	3116	5003	3256	1200
2			Alu4	5500		6004	3296	
3	250	PASP003	Alu3	3500		4003	3256	
4			Alu4	4500		5004	3296	
5			Alu5	5500		6004	3336	
6	500	PASP005	Alu3	2500		3003	3256	
7			Alu4	3500		4004	3296	
8			Alu5	4500		5004	3336	

Span, Height of Lift, Capacity and Model Number can be selected as per you requirement

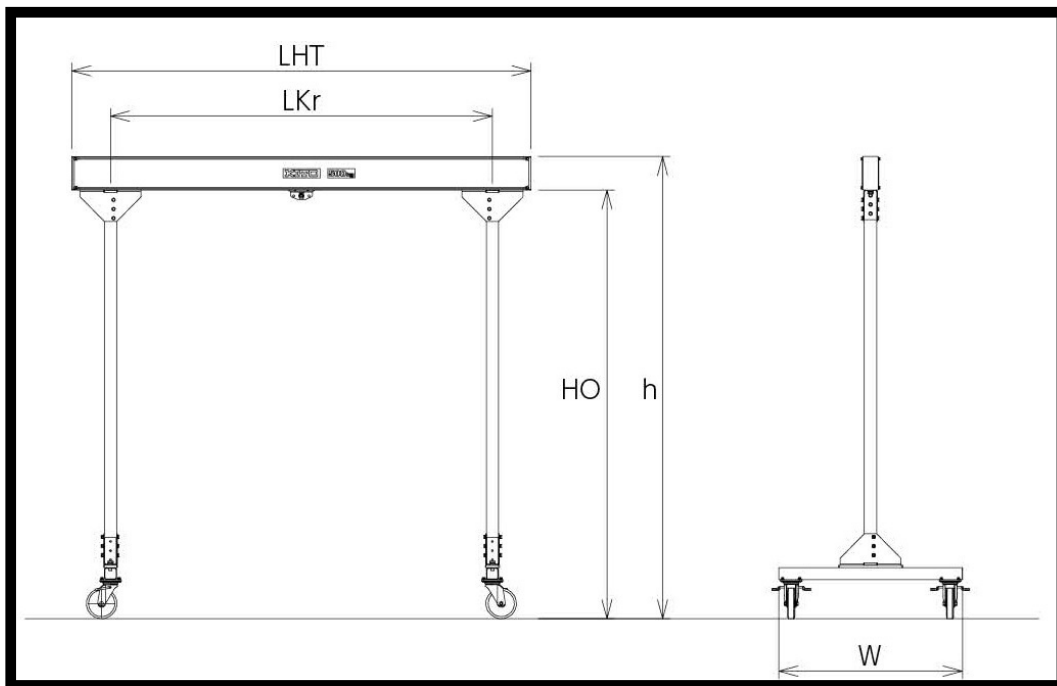

Dimensions

ADVANTAGES

- Additional structure is not required
- Easy to assemble; Easier to use!
- Light weight ALU rail makes it easy to move the system
- Castor is provided with in-built lock as a standard